

# ROHS

### NOTES:

#### A. Material:

1. Housing: PA9T
2. Contact: C7025, t=0.12mm 1U" middleclip SUS t=0.15mm  
焊接区g/f middleclip SUS t=0.15mm
3. Shell: Zinc Alloy, 表面镀镍30~50u" min

#### B. ELECTRICAL:

1. CURRENT RATING:  
VBUS AND GND CONTACTS RATED AT 1.25A  
PARALLELED FOR A TOTAL OF 3A
2. INITIAL CONTACT RESISTANCE: 40mΩ
3. DIELECTRIC WITHSTANDING VOLTAGE: 30V AC MIN

#### C. MECHANICAL CHARACTERISTICS:

1. MATING FORCE: 5~20N
2. UNMATING FORCE: 8~20N (INITIAL), 6~20N (AFTER 10000 CYCLES)
3. FREQUENCY: 200±50 CYCLES / HOUR, 10000 CYCLES
4. OPERATING TEMPERATURE: -40℃~80℃

#### D. WATERPROOF: IP-X7

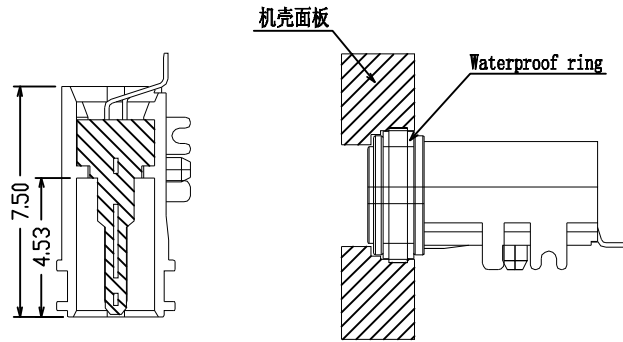
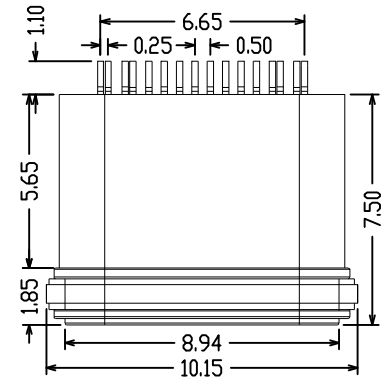

前后组装方式

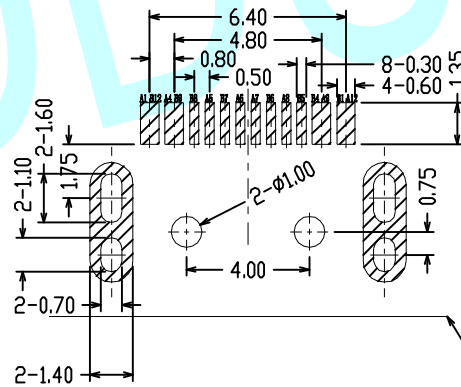
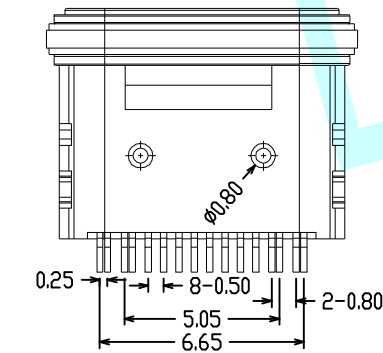
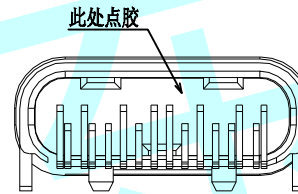
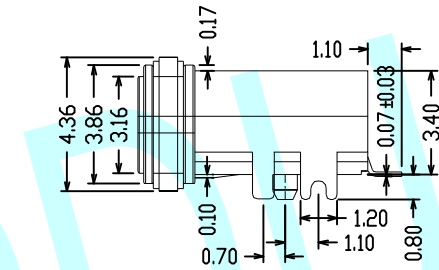
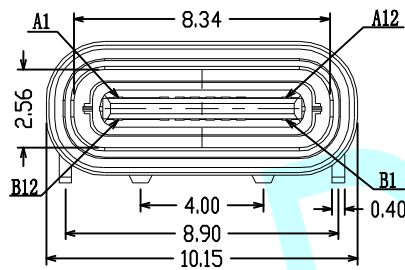

RECOMMENDED PCB LAYOUT  
TOLERANCE UNSPECIFIED ±0.05mm

A1	GND	B12	GND
A4	VBUS	B9	VBUS
A5	CC1	B8	SBU2
A6	DP1	B7	DN2
A7	DN1	B6	DP2
A8	SBU1	B5	CC2
A9	VBUS	B4	VBUS
A12	GND	B1	GND
PIN	SIGNAL NAME	PIN	SIGNAL NAME

APPROVALS		DATE	http://www.dongdudz.com		
DRAW:	ZRD	2023-12-6	TOLERANCE:	ANGLE:	
CHECKED:	***	***	30≥	±0.30	
APPOVALS:	***	***	10~30	±0.20	
			5~10	±0.15	
			≤5	±0.10	
			±2°	 <b>东都电子</b> DONGDU ELECTRONICS	
		MODBL:			USB CONNECTOR
		PART NO:			TYPE-C 16p-0442JG
		UNIT :mm			SCALE:1:1
		REV:	A	PAGE:1/1	