

ROHS

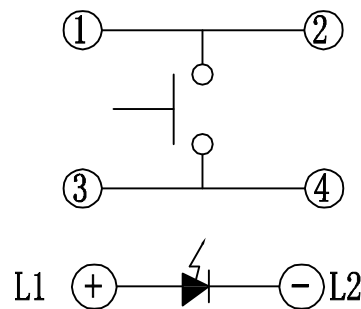

Circuit Diagram

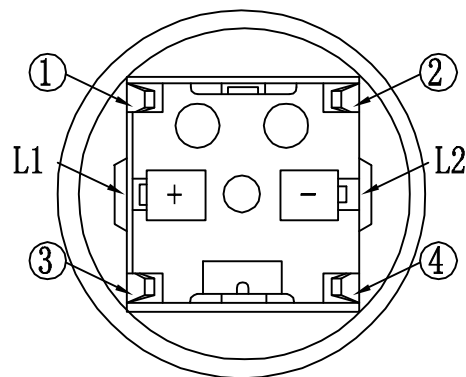
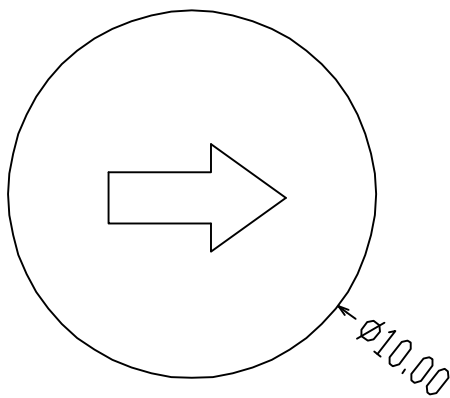
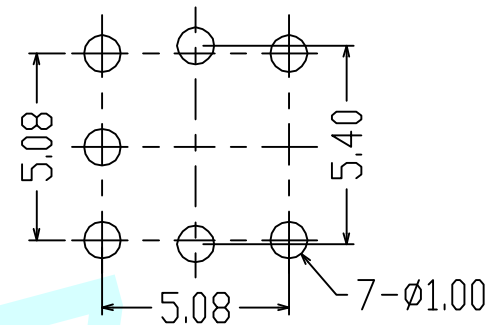

PCB Layout (Pattern Side)

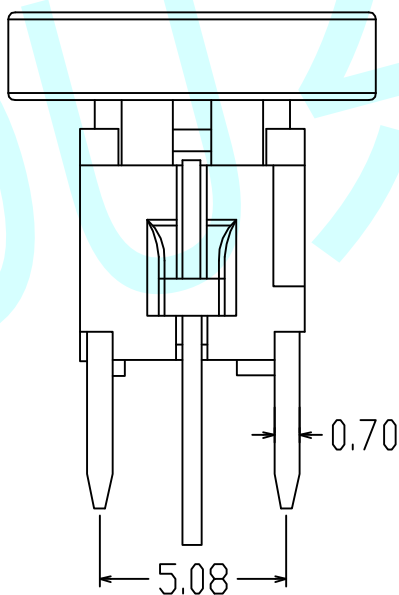
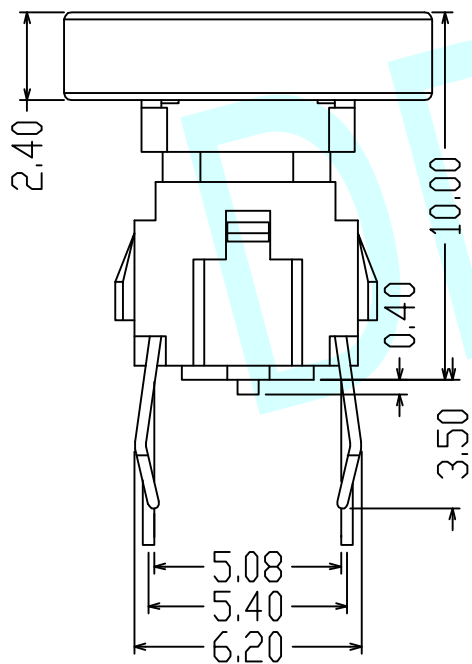

NOTES:

1. Rating: 12V DC 50mA
2. Contact Resistance: 100mΩ Max
3. Insulation Resistance: 100MΩ 250V DC FOR 1MIN
4. Dielectric Strength: 250V AC (50/60Hz) FOR 1MIN
5. Life Test: 100,000 Cycles
6. Operation Force: 160±50gf/250±50gf
7. Travel: 0.25±0.10mm
8. Operating temperature range: -20°C~+70°C

LED Colour (LED颜色)		Whiler (白色)	Red (红色)	Blue (蓝色)	Green (绿色)
APPROVALS		DATE	http://www.dongdudz.com		
DRAW:	ZRD	2017-12-6	TOLERANCE:	ANGLE:	
CHECKED:	***	****	30° ≥ ±0.30	±2°	
APPOVALS:	***	****	10°~30 ±0.20		
			5°~10 ±0.15		
			≤5 ±0.10		
				 东都电子 DONGDU ELECTRONICS	
				MODBL: LED Tact Switch PART NO: DDU-1512 UNIT :mm SCALE: 1:1	
				REV: A PAGE: 1/1	