

**ROHS**

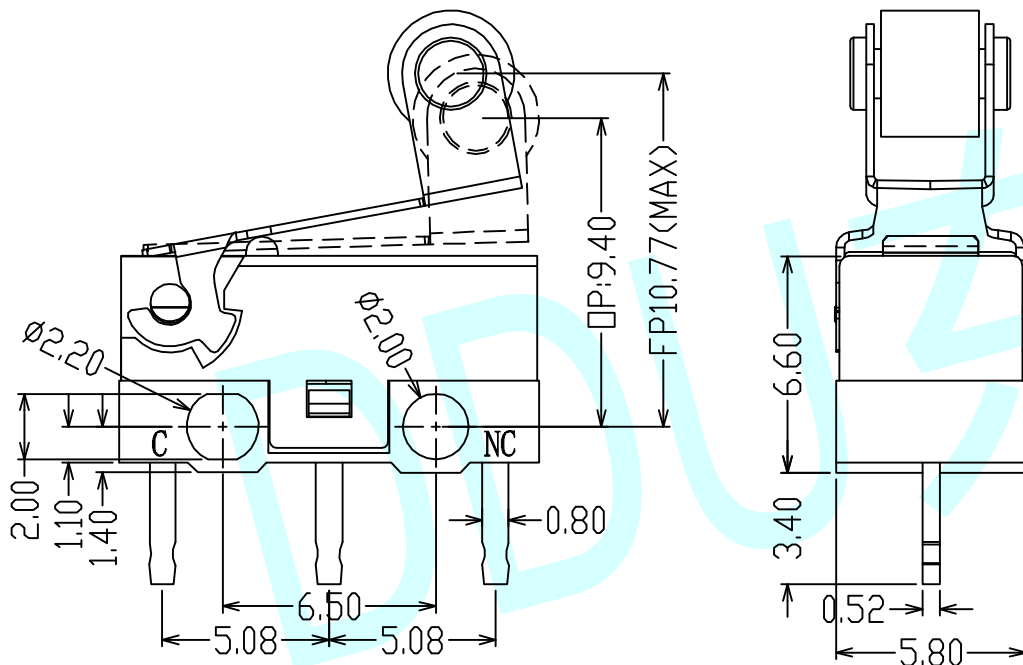

**NOTES:**

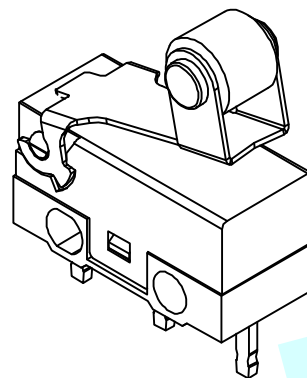
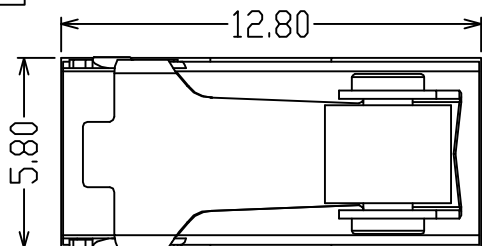
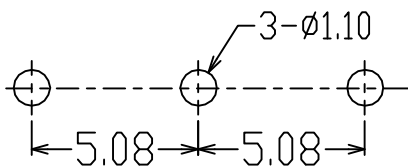

1. Rating: AC 125V 1A/DC 30V 0.1A
2. Contact Resistance: 50mΩ Max
3. Insulation Resistance: 100MΩ Min
4. High Voltage: AC 500V (50/60 Hz) for 1 minutes
5. Life: More Than 1 Million Times
6. Operating Force: 20±10gf
7. Release Force: 10gf Min

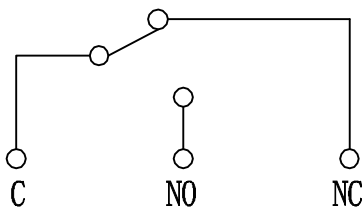

PCB Layout



Circuit Diagram

APPROVALS		DATE	http://www.dongdudz.com		 <b>东都电子</b> DONGDU ELECTRONICS
DRAW:	ZRD	2017-12-6	TOLERANCE:	ANGLE:	
CHECKED:	***	****	30°	±0.30	
APPOVALS:	***	****	10°30'	±0.20	
			5°10'	±0.15	
			≤5	±0.10	±2°
MODEL:	MICRO SWITCHS		UNIT :mm	SCALE: 1:1	
PART NO:	DDU-1715		REV:	A	PAGE: 1/1