

ROHS

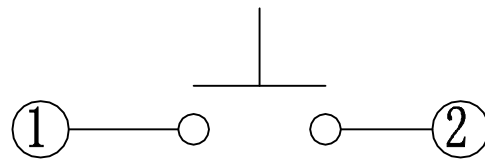

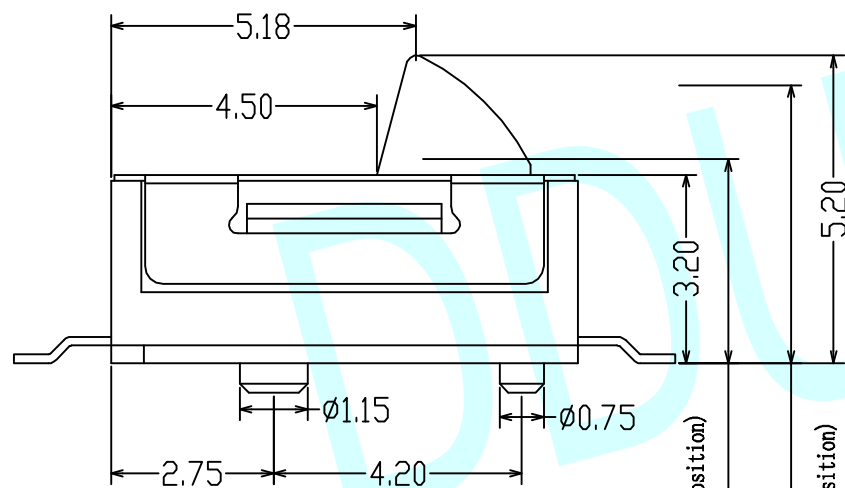

Circuit Diagram

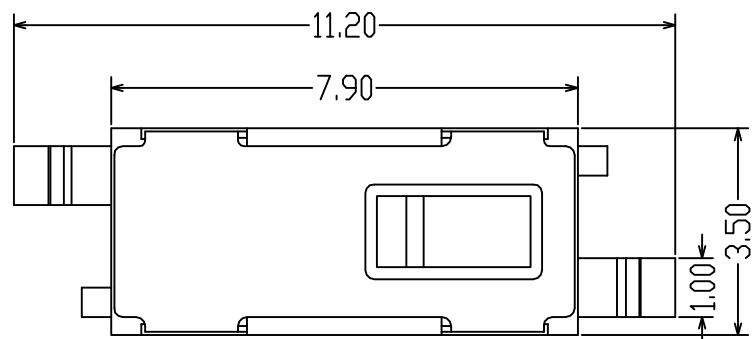
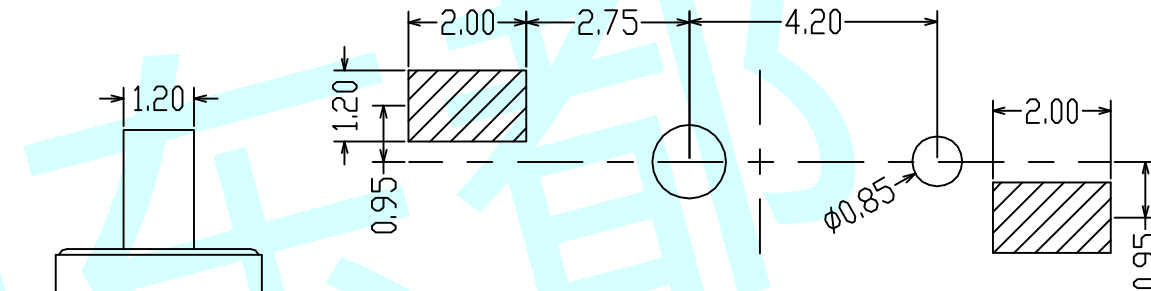

PCB Layout (Pattern Side)

NOTES:

1. Rating :DC 12V 50mA
2. Contact Resistance : $\leq 100m\Omega$
3. Insulation Resistance : $\geq 100m\Omega$  DC 500V
4. Operating Temperature Range : $-25^{\circ}C \sim +80^{\circ}C$
5. Ambient Humidity Used : $\leq 85\%RH$
6. Operating Force : $30gf \pm 20gf$
7. Life :100,000 Cycles

APPROVALS		DATE	http://www.dongdudz.com		 <b>® 东都电子</b> DONGDU ELECTRONICS	
DRAW:	ZRD	2017-12-6	TOLERANCE:	ANGLE:		
CHECKED:	***	****	30 $\geq$	$\pm 0.30$		$\pm 2^{\circ}$
APPOVALS:	***	****	10 $\sim$ 30	$\pm 0.20$		
			5 $\sim$ 10	$\pm 0.15$		
			$\leq 5$	$\pm 0.10$		
MODL:	DETECTOR SWITCHS		UNIT :mm	SCALE: 1:1		
PART NO:	DDU-1649		REV:	A		PAGE: 1/2