

ROHS

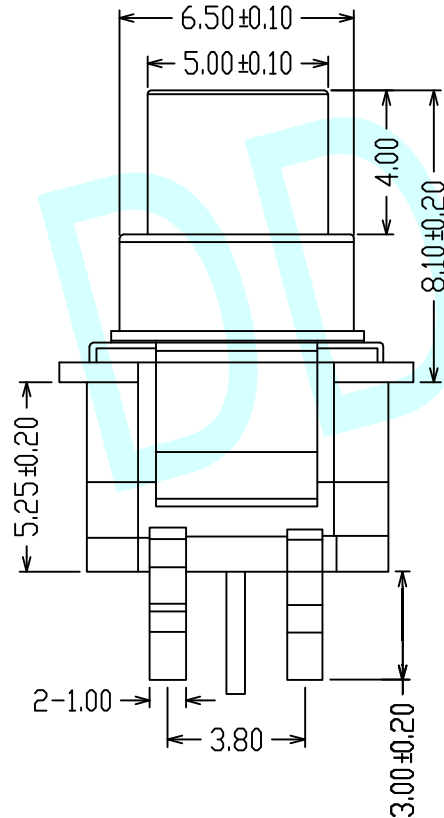

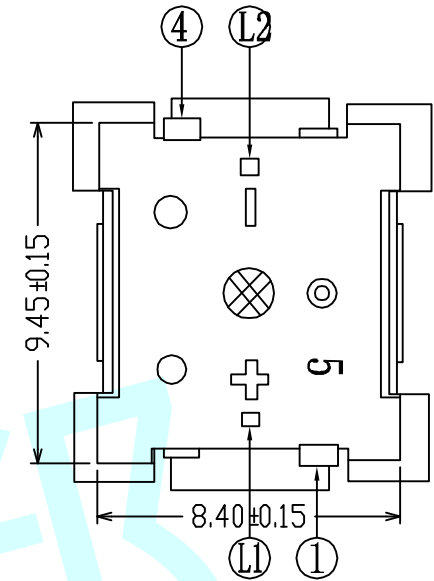
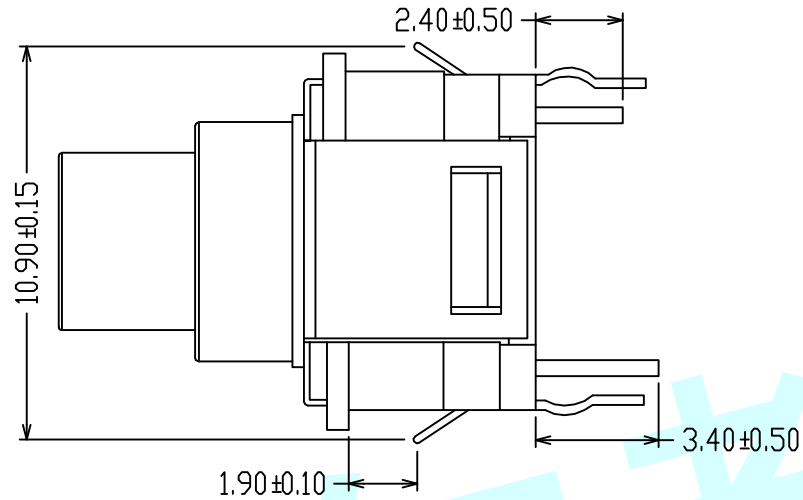
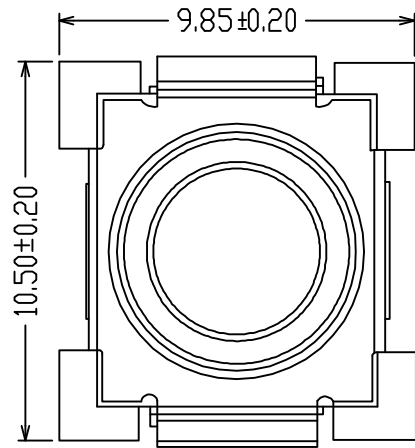
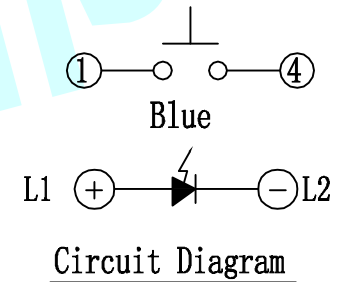

NOTES:

1. Rated current: DC 12V 50mA
2. Voltage resistance: AC 250 volt (50~60Hz)
Last 1 minutes
3. Contact impedance: 100mΩ Max
4. Insulation impedance 100MΩ Min 250V DC
5. Operating force : 450gf±100gf
6. Product life: 100,000 times
7. Pass stroke 1.20±0.25mm
8. Operation type: touch back type



Circuit Diagram

APPROVALS		DATE	http://www.dongdudz.com		 ® 东都电子 DONGDU ELECTRONICS
DRAW:	ZRD	2017-12-6	TOLERANCE:	ANGLE:	
CHECKED:	***	****	30°	±0.30	±2°
APPOVALS:	***	****	10°30'	±0.20	
			5°10'	±0.15	
			≤5	±0.10	
MODBL:	LED Tact Switch		UNIT : mm	SCALE: 1:1	
PART NO:	DDU-1503		REV:	A	PAGE: 1/1