

ROHS

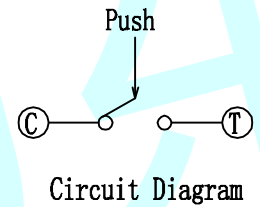
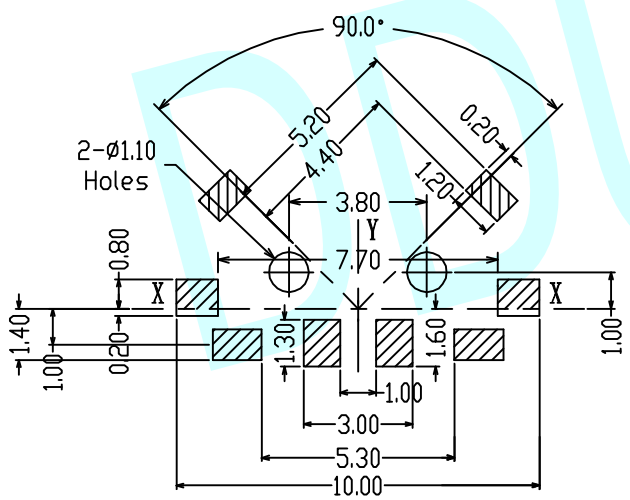
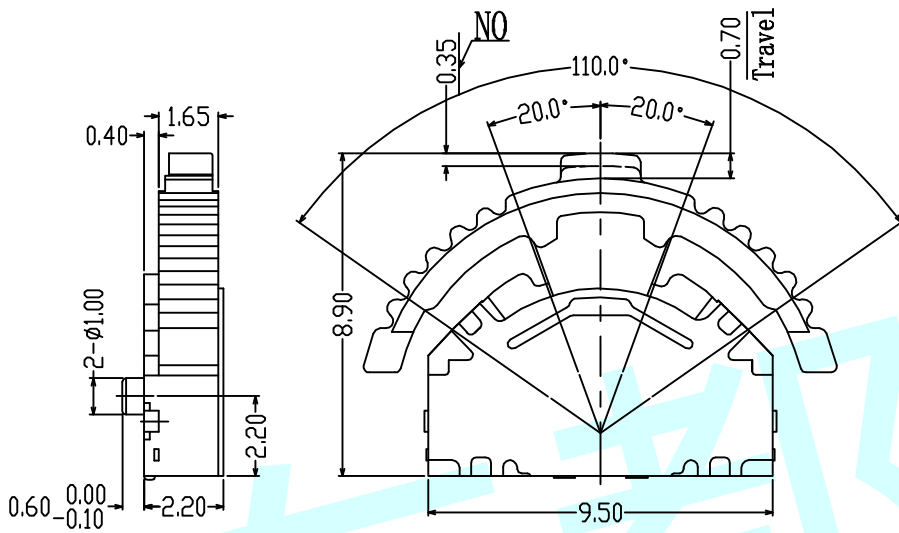
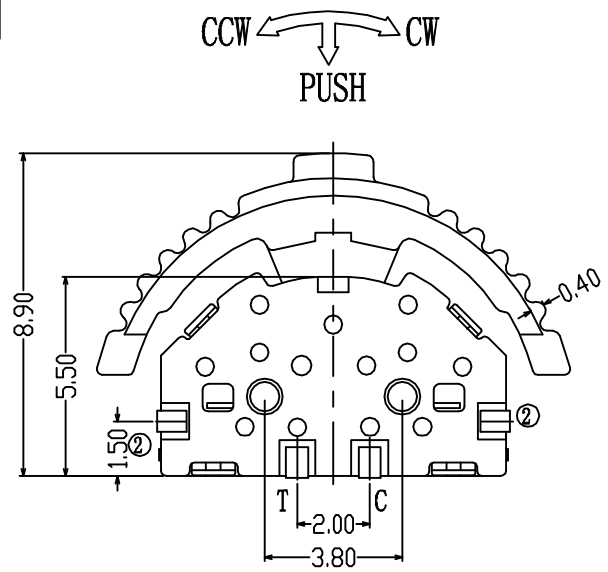

0° (NO)

TER	ANG.	(20°)	(15°)	(15°)	(20°)
①		▨			
②					▨
③		▨	▨	▨	▨

CCW ← → CW

NOTES:

1. Rating: DC 5V 10mA
2. Contact resistance: 100mΩ MAX
3. Insulation resistance: 100MΩ MIN
4. Service life: 100,000 cycles
5. Operating temperature: -25°C ~ +85°C
6. Using humidity: ≤85% RH
7. Operating power: 70/250 ± 40gf

CODE TABLE

**PCB Mounting
Pattern Dimension**

APPROVALS		DATE	http://www.dongdudz.com	
DRAW:	ZRD	2017-12-6	TOLERANCE:	ANGLE:
CHECKED:	***	****	30 ≥ ±0.30	±2°
APPOVALS:	***	****	10~30 ±0.20	
			5~10 ±0.15	
			≤5 ±0.10	
			东都电子 DONGDU ELECTRONICS	
MODL:		ROCKER SWITCH		
PART NO:		DDU-1209		
UNIT :mm	SCALE: 1:1			
REV:	A	PAGE: 1/1		