

ROHS

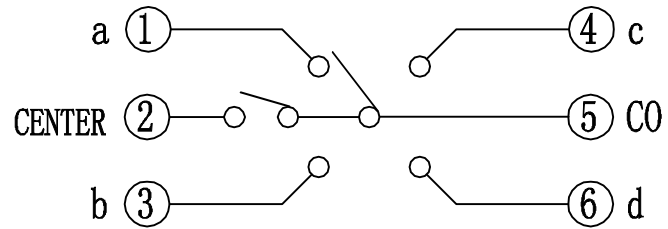

Circuit Diagram

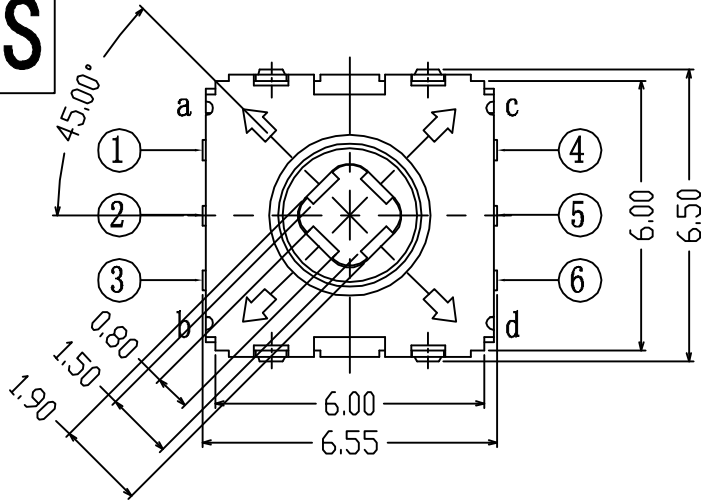
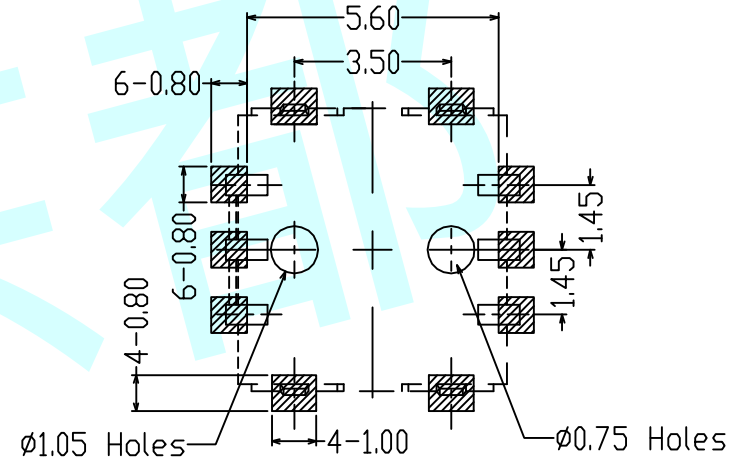
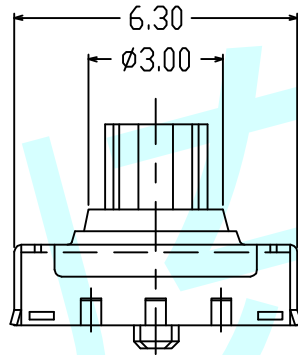
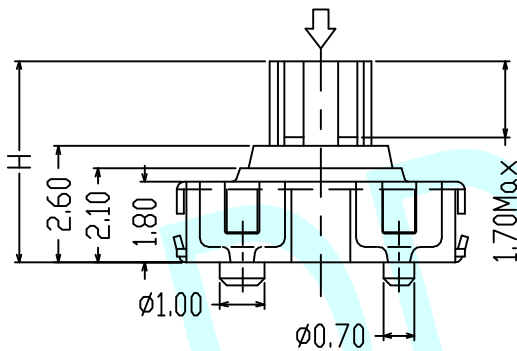

PCB Layout (Pattern Side)

NOTES:

1. Rating :DC 12V 50mA
2. Contact Resistance :80mΩ MAX
3. Insulation Resistance :100mΩ MIN
4. Mechanical Life :100,000 Cycles
5. Ambient Temper. used :-25°C~85°C
6. Ambient Humidity Used:85% RH
7. Operating Forec:
 4-Direction: 160±35gf
 Center Oush: 250±35gf

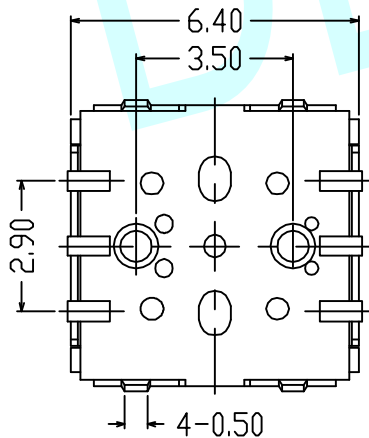

H	4.50	5.00
---	------	------

APPROVALS		DATE	http://www.dongdudz.com	
DRAW:	ZRD	2017-12-6	TOLERANCE:	ANGLE:
CHECKED:	***	****	30≥	±0.30
APPOVALS:	***	****	10~30	±0.20
			5~10	±0.15
			≤5	±0.10
			±2°	



MODEL:	ROCKER SWITCH	
PART NO:	DDU-1231	
UNIT :mm	SCALE:1:1	☞
REV:	A	PAGE:1/1