

ROHS

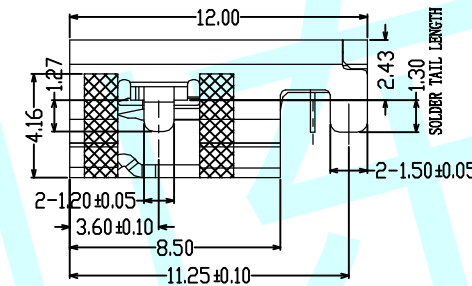
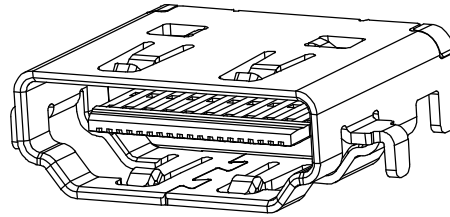
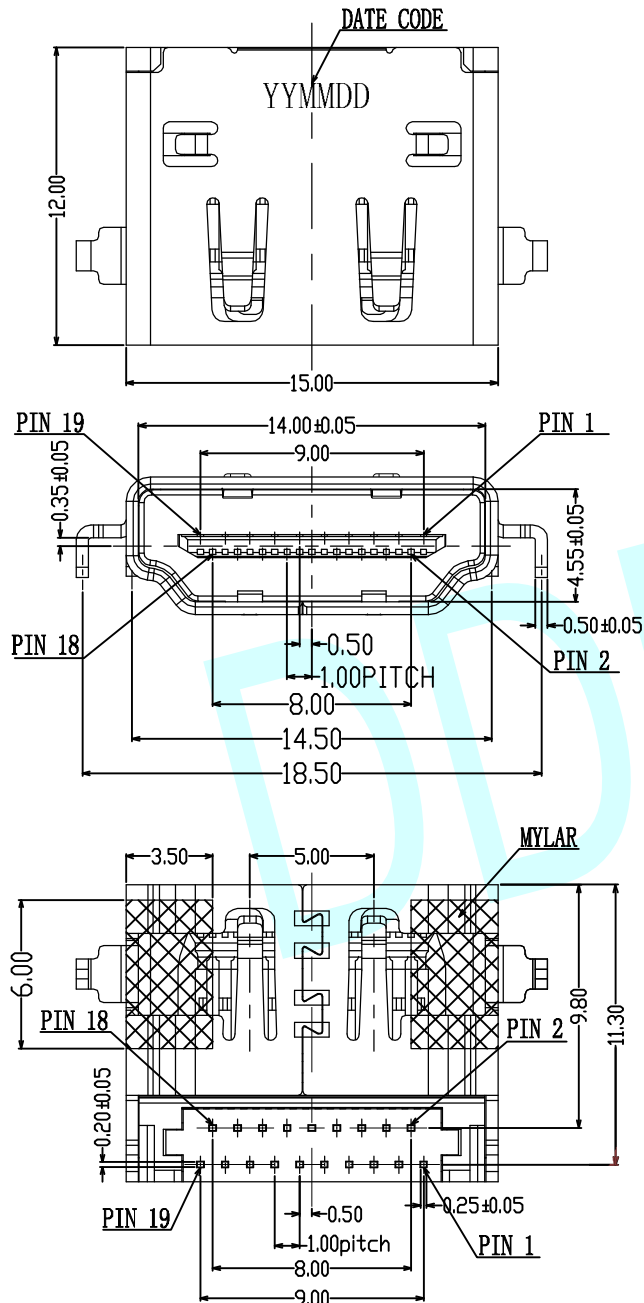

NOTES:

A. ELECTRONIC:

1. Contact resistance: 20mΩ max
2. Insulation resistance: 1000MΩ min
3. Withstand voltage: AC 500V 1min

B. Mechanical:

1. Durability: 10000 cycles

C. Environment characteristics:

1. Operating temperature: -55°C~+105°C

D. Recommender PCB thickness: 1.20mm~1.60mm

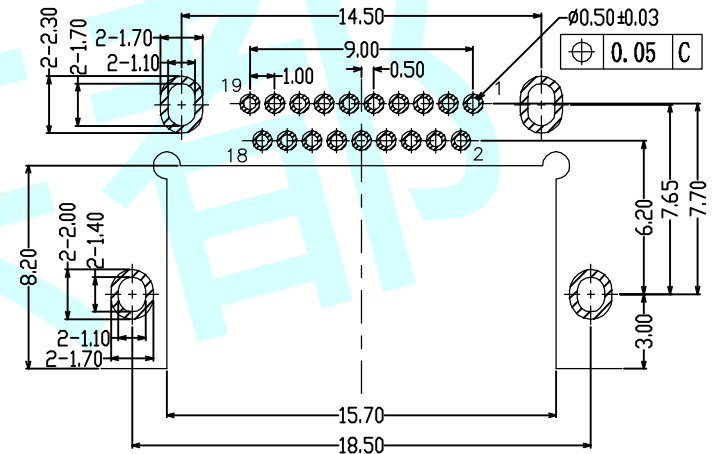

RECOMMENDED PCB LAYOUT T=1.60
GENERAL TOLERANCES: ±0.05 (TOP VIEW)

No.	PART NAME	Q' TY	MATERIAL	REMARK
3	SHELL	1	COPPER ALLOY C2680 T=0.50	NI PLATED
2	CONTACT	19	COPPER ALLOY T=0.20	AU/TIN PLATED
1	HOUSING	1	THERMOPLASTIC	(UL 94V-0) BLACK

APPROVALS		DATE	http://www.dongdudz.com	
DRAW:	ZRD	2017-12-6	TOLERANCE:	ANGLE:
CHECKED:	***	***	30°	±0.30
APPOVALS:	***	***	10°30'	±0.20
			5°10'	±0.15
			≤5	±0.10

® 东都电子
DONGDU ELECTRONICS

MODEL: USB CONNECTOR
PART NO: HDMI-19P-C2.43
UNIT :mm SCALE: 1:1
REV: A PAGE: 1/1